

## ZSM2101-103126 (Order no. 103126)

### ZSM, LED, + and – buttons, vibration motor, stop command device, key-operated rotary switch

- ▶ 3-stage function
- ▶ Stop command device
- ▶ Vibration signal
- ▶ LED indicator
- ▶ + and – buttons
- ▶ Key-operated rotary switch
- ▶ Straight connecting cable, 5 m



#### 3-stage function

Enabling function is active only in the second stage (center position, actuating point). If the pushbutton is released or pushed further (panic function), the enabling is removed (dependent on the wiring, see function sequence).

#### Stop command device

Dual-channel emergency stop device (red, with pull-to-reset and turn-to-reset button) on the switch housing, for different wiring concepts.

Lower position, protected by anti-kink strain relief in case of a fall.

#### Vibration signal

The vibration signal is used for tactile feedback of the enabling position.

#### LED indicator

The LED indicator is used for visual feedback directly at the enabling switch.

#### + and – buttons

These pushbuttons can be configured individually. For example, for moving axes in the positive or negative direction.

#### Key-operated rotary switch

For individual use, e.g. as an operating mode selector.

#### Cable

The high-quality connecting cables are available in a straight version.

**Dimensional drawings**

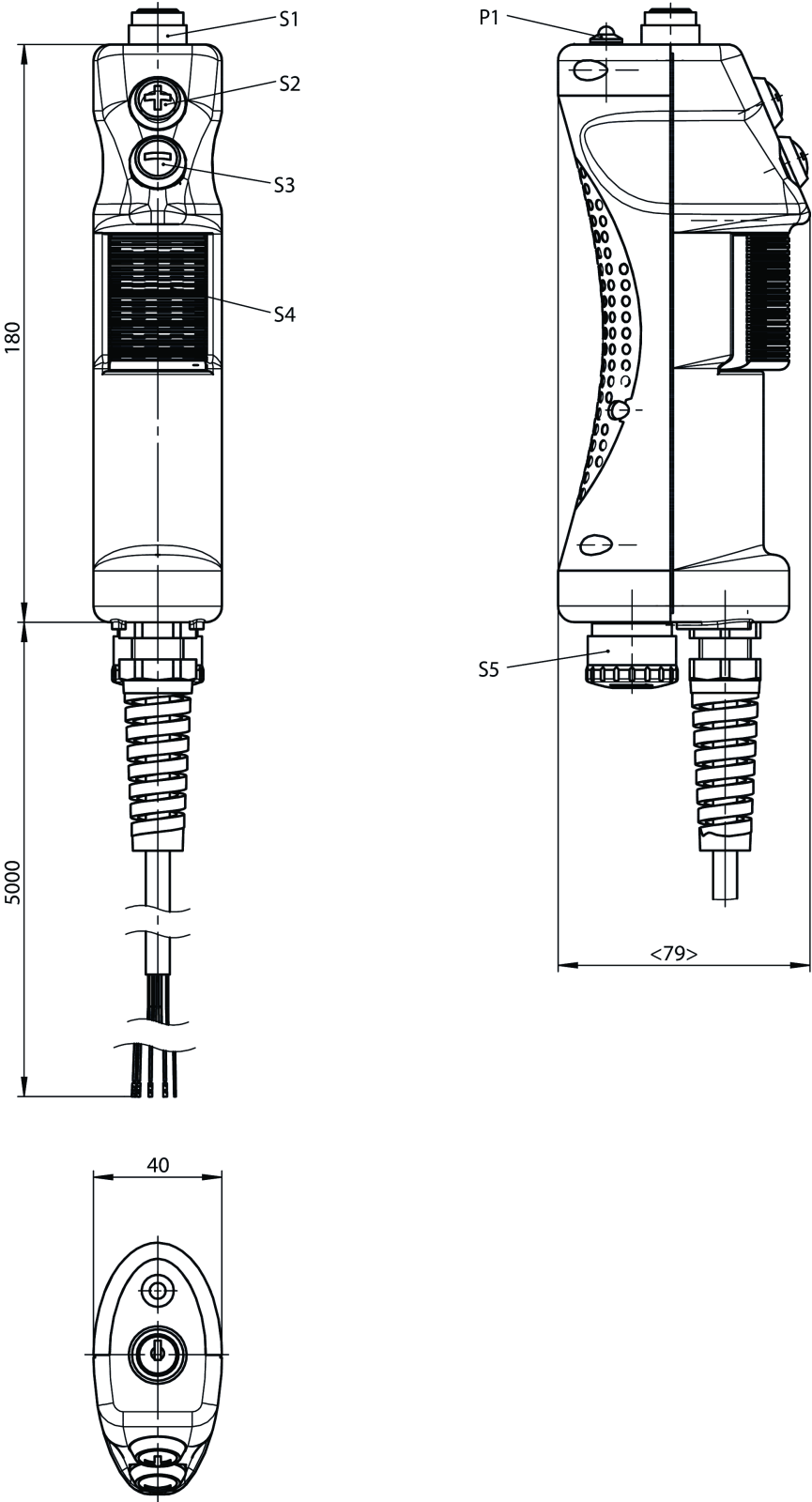

## Connection examples

**S1:**  
Schlüsselschalter  
key switch

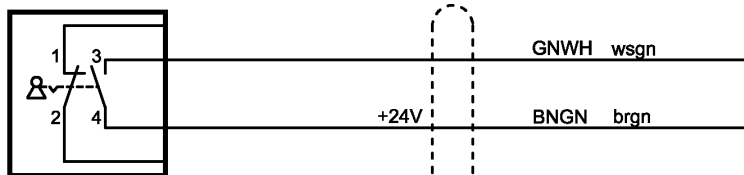

**S2: "+"**  
Drucktaste  
pushbutton

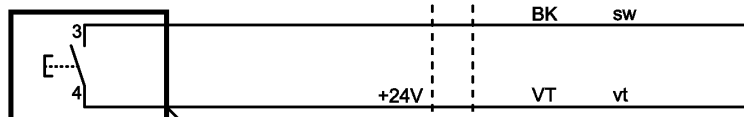

**S3: "-"**  
Drucktaste  
pushbutton

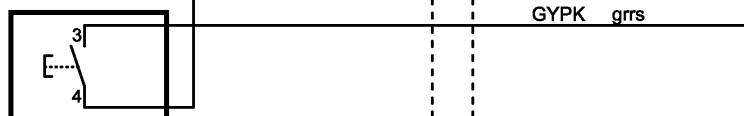

**V1:**  
LED gelb  
LED yellow

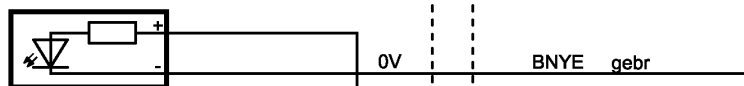

**S4:**  
Zustimmtaster  
enabling pushbutton

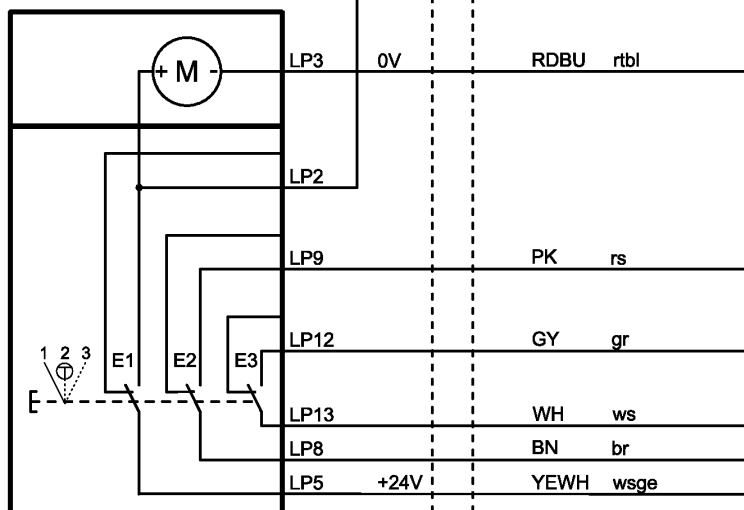
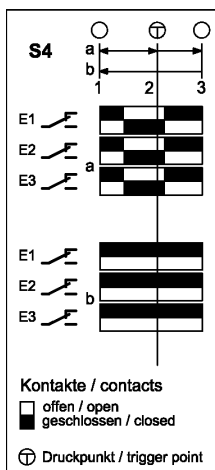

**S5:**  
Not-Halt  
emergency-stop

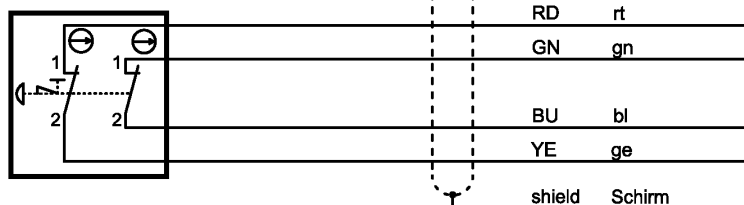

Leitung / cable:  
23x0,14mm<sup>2</sup>

Connection examples

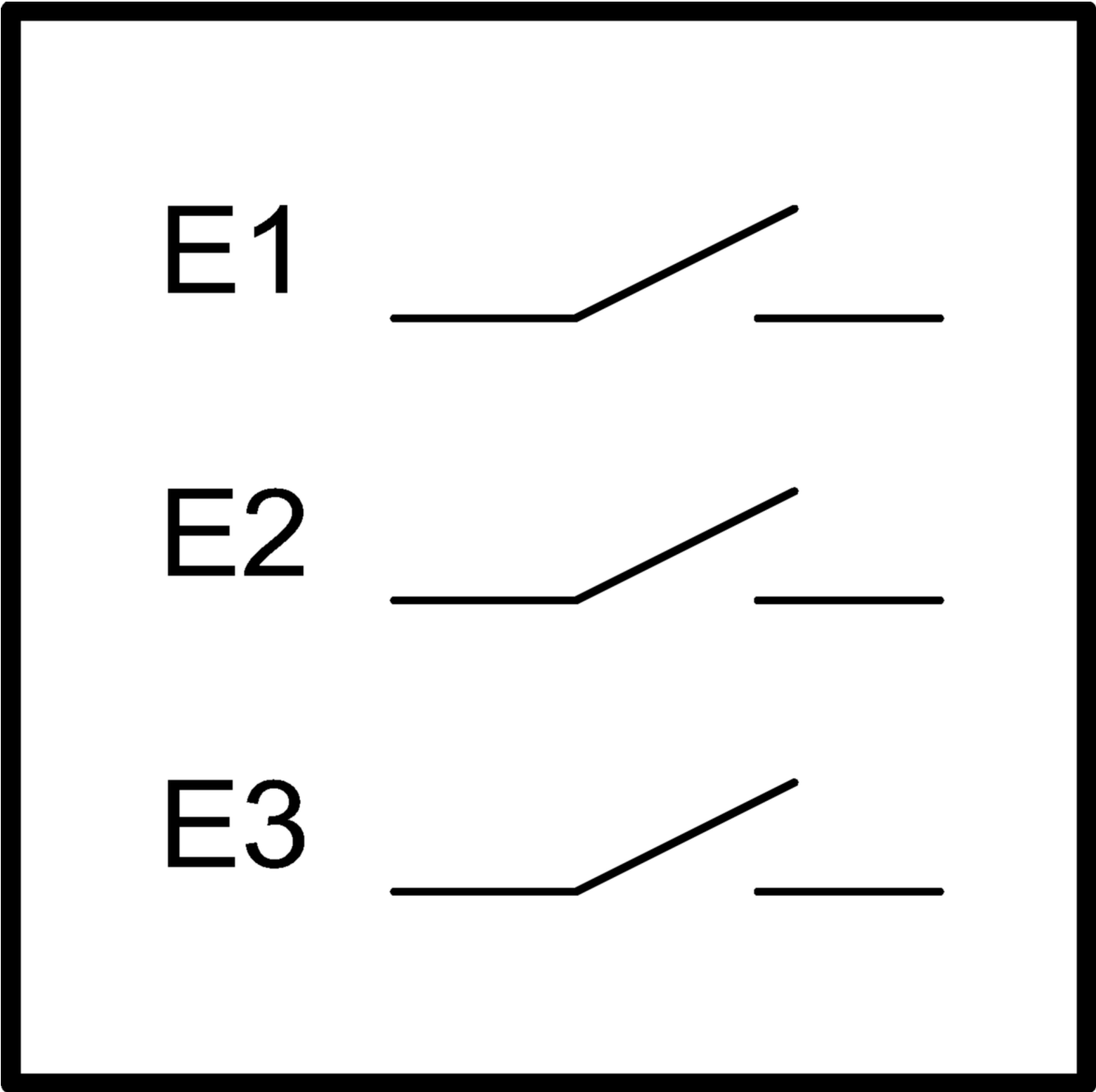

## Connection examples

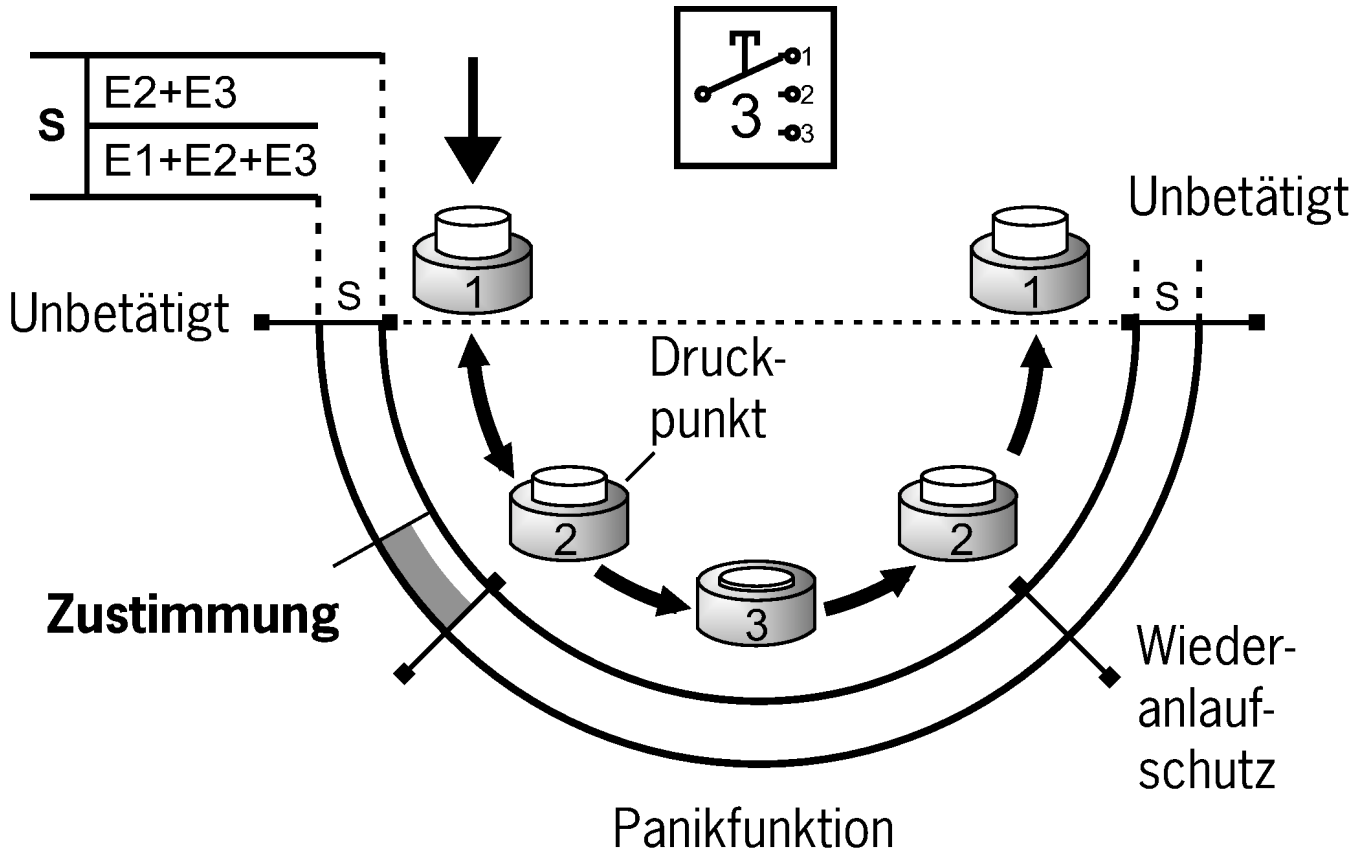

## Technical data

### Approvals



### Operating and display elements

Item	Extras	Color	Designation1	Number	LED	Switching element	Note slide-in label	Slide-in label	Version
				1					- button
				1					Key-operated rotary switch
				1					Emergency stop device
		Yellow		1					LED
				1					+ button
				1					Vibration motor

### Electrical connection values

Connecting cable	23x0.14 mm <sup>2</sup> (screened)
rated conditional short-circuit current	100 A
Rated insulation voltage U <sub>i</sub>	250 V
Rated impulse withstand voltage U <sub>imp</sub>	1.5 kV
Utilization category	
	DC-13 24 V 0.3 A (For additional controls)
	DC-13 24 V 0.01 A (For additional indicators)
	DC-13 30V 0.1A (For enabling switch, Caution! Outputs must be protected with a free-wheeling diode for inductive loads.)

Short circuit protection according to IEC 60269-1	2A gG (In case of operating voltages other than 24 V, the short circuit protection must be dimensioned accordingly and checked.)
---	---

Switching characteristics	3-stage enabling switch
---------------------------	-------------------------

Degree of contamination (external, according to EN 60947-1)	3
---	---

## Mechanical values and environment

Connection type	flying lead
-----------------	-------------

Number of changeover contacts	3 (Connection as per block diagram)
-------------------------------	--

Cable length	
	straight 5 m

Mechanical life	1 x 10 <sup>6</sup>
-----------------	---------------------

Switching principle	Snap-action contact element
---------------------	-----------------------------

Degree of protection	IP54
----------------------	------

Ambient temperature	-5 ... +60 °C
---------------------	---------------

Material	PA, CR, TPE (Low PAH)
----------	--------------------------

## Characteristic values according to EN ISO 13849-1 and EN IEC 62061

### Emergency stop

B <sub>10D</sub>	0.1 x 10 <sup>6</sup>
------------------	-----------------------

### Enabling switch

B <sub>10D</sub>	0.1 x 10 <sup>6</sup>
------------------	-----------------------

## Miscellaneous

in compliance with	60947-5-8
--------------------	-----------

## Downloads

All documentation for this material can be found on our website:

<https://www.euchner.de/en-us/a/103126/?#downloads-tab>



**Ordering data**

Ordernumber	103126
Item designation	ZSM2101-103126
Gross weight	0,938kg
Customs tariff number	85371098
ECLASS	27-37-12-38 Agreement switch

## Accessories

### Connection accessories

Blanking plug RC17 for covering the flange connector RC17



**096159**

BLINDSTECKER 17-POL RC-17P1N8A83NN

Plug connector RC17 for connection to enabling switches, for example



**096481**

STECKVERBINDER 17POL RC-17P1N8A80CP

### Mounting accessories

Holder for ZSM



**102965**

HALTER MIT MAGNET ZSM

▶ Magnet mounting



**102969**

HALTER ZSM

▶ Screw mounting